



RANGE SUMMARY



Sealed Rechargeable, Valve Regulated Lead-Acid Batteries

GENERAL SPECIFICATIONS

GENESIS NP SERIES

Type	FR Type*	Volts	Nominal Capacity (20 hr rate - Ah)	Length		Width		Overall Height Incl. Terminals		Approx Weight		Layout	Terminals
				mm.	(in.)	mm	(in.)	mm.	(in.)	kgs.	(lbs.)		
NP1.2-6	NP1.2-6FR	6	1.2	97.0	3.82	24.0	0.95	54.5	2.14	0.30	0.66	1	A
NP2.8-6	NP2.8-6FR		2.8	66.0	2.60	33.0	1.30	104.0	4.09	0.59	1.30	2	A
NP3-6	NP3-6FR		3.4	134.0	5.28	34.0	1.34	64.0	2.52	0.69	1.52	1	A
NP4-6	NP4-6FR		4.0	70.0	2.76	47.0	1.85	106.0	4.17	0.80	1.76	5	A/C
NP4.5-6	NP4.5-6FR		4.5	70.0	2.76	47.0	1.85	106.0	4.17	0.85	1.87	5	A/C
NP7-6	NP7-6FR		7.0	151.0	5.95	34.0	1.34	97.5	3.84	1.34	2.95	1	A/C
NP8.5-6	NP8.5-6FR		8.5	98.5	3.88	56.2	2.21	117.7	4.63	1.60	3.53	6	A/C
NP10-6	NP10-6FR		10.0	151.0	5.95	50.0	1.97	97.5	3.84	2.05	4.52	1	A/C
NP12-6	NP12-6FR		12.0	151.0	5.95	50.0	1.97	97.5	3.84	2.15	4.74	1	C
NP0.8-12	NP0.8-12FR**		12	0.8	96.0	3.78	25.0	0.98	62.4	2.46	0.37	0.82	7
NP1.2-12	NP1.2-12FR	1.2		97.0	3.82	47.0	1.85	55.5	2.18	0.56	1.23	3	A
NP2-12	NP2-12FR	2.0		150.0	5.91	20.0	0.79	89.5	3.52	0.68	1.50	8	B
NP2-12C	NP2-12CFR	2.0		182.0	7.17	23.7	0.93	61.3	2.41	0.78	1.76	9	D
NP2.3-12	NP2.3-12FR	2.3		178.0	7.01	35.0	1.38	64.0	2.52	0.96	2.12	1	A
NP2.9-12	NP2.9-12FR	2.9		79.0	3.11	56.0	2.20	105.0	4.13	1.21	2.67	2	A
NP3-12	NP3-12FR	3.0		132.0	5.20	33.0	1.30	104.5	4.11	1.20	2.65	1	A
NP3.4-12	NP3.4-12FR	3.4		134.0	5.28	67.0	2.64	64.0	2.52	1.37	3.02	3	A
NP4-12	NP4-12FR	4.0		90.0	3.54	70.0	2.76	107.0	4.21	1.60	3.53	1	A/C
NP5-12	NP5-12FR	5.0		89.6	3.53	69.6	2.74	107.0	4.21	1.76	3.83	1	A/C
NP7-12	NP7-12FR	7.0		151.0	5.95	65.0	2.56	97.5	3.84	2.59	5.71	4	A/C
NP12-12	NP12-12FR	12.0		151.0	5.95	98.0	3.86	97.5	3.84	4.06	8.95	4	C
NP18-12	NP18-12FR	17.2		181.0	7.13	76.2	3.00	167.0	6.58	6.06	13.36	2	F
NP24-12	NP24-12FR	25.0		166.0	6.54	175.0	6.89	125.0	4.92	8.80	19.40	2	F
NP33-12	NP33-12FR	33.0		195.5	7.70	130.0	5.12	179.0	7.05	12.30	27.12	1	E/F
NP38-12	NP38-12FR	40.0		197.0	7.76	165.0	6.50	170.0	6.99	15.03	33.14	2	F
NP55-12	NP55-12FR	55.0		229.0	9.02	138.0	5.43	228.0	8.98	18.20	40.12	1	I
NP65-12	NP65-12FR	65.0		349.8	13.78	166.0	6.54	174.0	6.85	22.00	48.50	2	I
NP75-12	NP75-12FR	75.0		259.0	10.20	168.0	6.61	227.0	8.94	26.50	58.42	1	I
NP90-12	NP90-12FR	90.0		304.0	11.97	168.0	6.50	229.0	9.02	30.50	67.24	1	I
NP100-12	NP100-12FR	100.0	329.0	12.95	172.0	6.77	221.0	8.70	34.10	75.18	1	I	
NP120-12	NP120-12FR	120.0	407.0	16.02	173.0	6.81	234.5	9.23	41.3	91.05	1	I	
NP150-12	NP150-12FR	150.0	483.0	19.02	170.0	6.69	241.0	9.49	46.8	103.17	1	I	
NP200-12	NP200-12FR	200.0	520.0	20.47	260.0	10.24	240.0	9.45	73.00	160.93	3	I	

FOOTNOTES

UL listing pending - File No. MH16464

* FR: UL94-V0, Flame Retardant Container and Lid (Oxygen index: 30)

** FR: UL94-V2, Flame Retardant Container and Lid (Oxygen index: 30)

Dimension tolerance \pm 1mm (0.04 in)

• LAYOUT

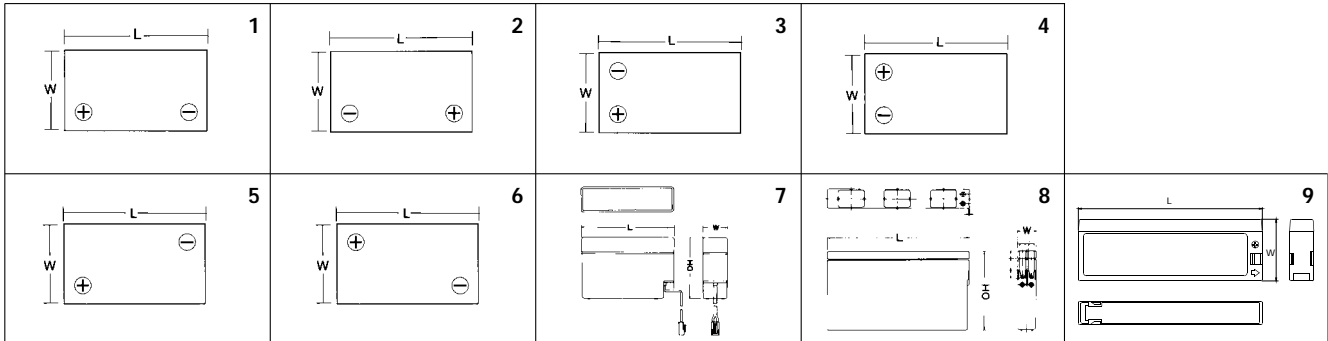

• TERMINAL

<p>Faston tab : 187 A</p> <table border="1"> <thead> <tr> <th colspan="2">INCH = MM</th> </tr> </thead> <tbody> <tr><td>.250</td><td>6.35</td></tr> <tr><td>.185</td><td>4.70</td></tr> <tr><td>.124</td><td>3.15</td></tr> <tr><td>.098</td><td>2.50</td></tr> <tr><td>.059</td><td>1.50</td></tr> <tr><td>.031</td><td>0.80</td></tr> <tr><td>.020</td><td>0.50</td></tr> <tr><td>.004</td><td>0.10</td></tr> </tbody> </table>	INCH = MM		.250	6.35	.185	4.70	.124	3.15	.098	2.50	.059	1.50	.031	0.80	.020	0.50	.004	0.10	<p>Faston tab : 187 B</p> <table border="1"> <thead> <tr> <th colspan="2">INCH = MM</th> </tr> </thead> <tbody> <tr><td>.472</td><td>12.0</td></tr> <tr><td>.250</td><td>6.35</td></tr> <tr><td>.236</td><td>6.00</td></tr> <tr><td>.185</td><td>4.70</td></tr> <tr><td>.079</td><td>2.00</td></tr> <tr><td>.020</td><td>0.50</td></tr> </tbody> </table>	INCH = MM		.472	12.0	.250	6.35	.236	6.00	.185	4.70	.079	2.00	.020	0.50	<p>Faston tab : 250 C</p> <table border="1"> <thead> <tr> <th colspan="2">INCH = MM</th> </tr> </thead> <tbody> <tr><td>.250</td><td>6.35</td></tr> <tr><td>.124</td><td>3.15</td></tr> <tr><td>.098</td><td>2.50</td></tr> <tr><td>.059</td><td>1.50</td></tr> <tr><td>.031</td><td>0.80</td></tr> <tr><td>.020</td><td>0.50</td></tr> </tbody> </table>	INCH = MM		.250	6.35	.124	3.15	.098	2.50	.059	1.50	.031	0.80	.020	0.50
INCH = MM																																																
.250	6.35																																															
.185	4.70																																															
.124	3.15																																															
.098	2.50																																															
.059	1.50																																															
.031	0.80																																															
.020	0.50																																															
.004	0.10																																															
INCH = MM																																																
.472	12.0																																															
.250	6.35																																															
.236	6.00																																															
.185	4.70																																															
.079	2.00																																															
.020	0.50																																															
INCH = MM																																																
.250	6.35																																															
.124	3.15																																															
.098	2.50																																															
.059	1.50																																															
.031	0.80																																															
.020	0.50																																															
<p>Camcorder Type D</p> <table border="1"> <thead> <tr> <th colspan="2">INCH = MM</th> </tr> </thead> <tbody> <tr><td>0.87</td><td>22.0</td></tr> <tr><td>0.55</td><td>14.0</td></tr> <tr><td>0.43</td><td>11.0</td></tr> <tr><td>0.25</td><td>6.35</td></tr> </tbody> </table>	INCH = MM		0.87	22.0	0.55	14.0	0.43	11.0	0.25	6.35	<p>Bolt fastened terminal E</p> <table border="1"> <thead> <tr> <th colspan="2">INCH = MM</th> </tr> </thead> <tbody> <tr><td>0.24</td><td>6.00</td></tr> <tr><td>0.27</td><td>7.00</td></tr> <tr><td>0.37</td><td>9.50</td></tr> <tr><td>0.71</td><td>18.0</td></tr> <tr><td>0.768</td><td>19.5</td></tr> </tbody> </table>	INCH = MM		0.24	6.00	0.27	7.00	0.37	9.50	0.71	18.0	0.768	19.5	<p>Receptacle F</p>																								
INCH = MM																																																
0.87	22.0																																															
0.55	14.0																																															
0.43	11.0																																															
0.25	6.35																																															
INCH = MM																																																
0.24	6.00																																															
0.27	7.00																																															
0.37	9.50																																															
0.71	18.0																																															
0.768	19.5																																															
<p>Tyco. 1-480318-0 G</p>	<p>JST No. VHR-2N H</p>	<p>Receptacle I</p>																																														

Charging

- Standby use: Apply constant voltage charging at 2.275Vpc (or 2.25-2.30Vpc).
- Cyclic use: Apply constant voltage charging at 2.40-2.45Vpc. Initial charging current should be set at less than 0.25CA.
- Top charge: Product in storage (ambient temperature 25°C/77°F) requires a top charge every six months. Apply constant voltage at 2.40Vpc, initial charging current should be set at less than 0.1CA for 15 to 20 hours.

Discharge

- Stop operation when voltage has reached the minimum permissible voltage. Recharge immediately.
- Do not operate at 6CA or more current continuously.

Storage

- Always store battery in a fully charged condition.
- If battery is to be stored for a long period, apply a recovery top-charge every 6 months.
- Store batteries in a dry and cool location.

Temperature

- Keep within ambient temperatures of -15°C to 50°C for both charging and discharging.

Incorporating battery into equipment

- Encase battery in a well ventilated compartment.
- Avoid installing battery near heated units such as a transformer.
- House the battery in the lowest section of the equipment enclosure or rack to prevent unnecessary battery temperature rise.

Others

- Avoid terminal short circuit.
- DO NOT expose to open flame.
- Avoid setting batteries in environments which can cause direct contact to petrol, paint thinner, organic solvents, synthetic resins, oil, etc.

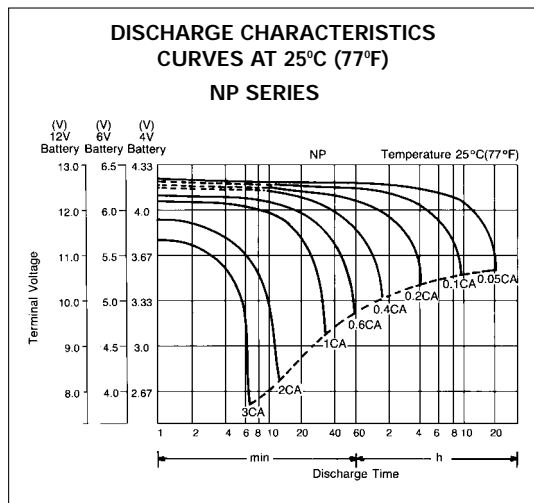
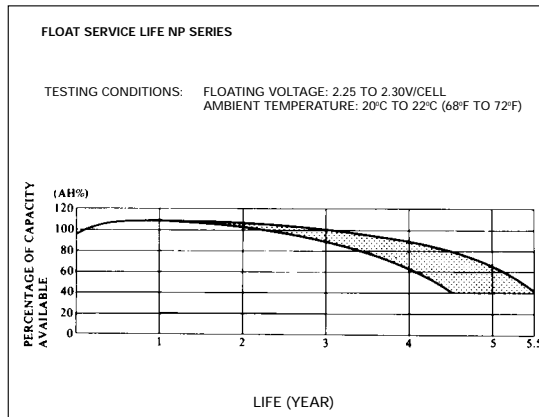
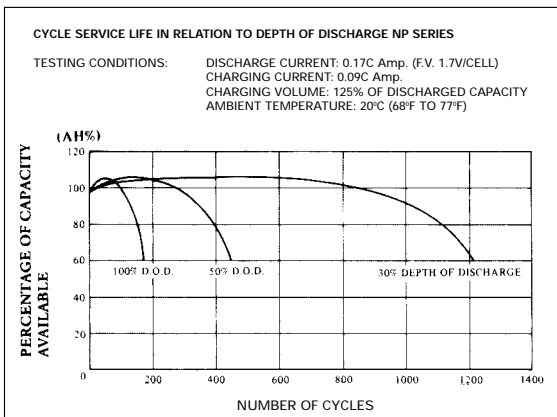
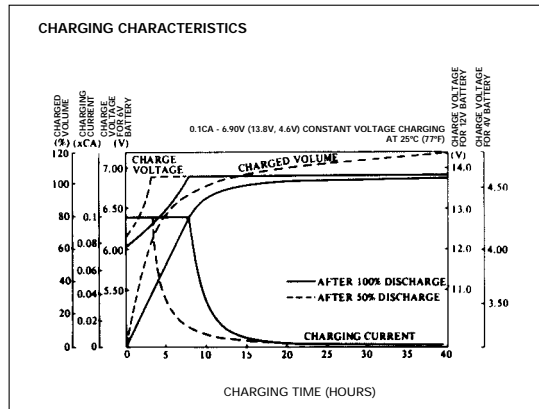
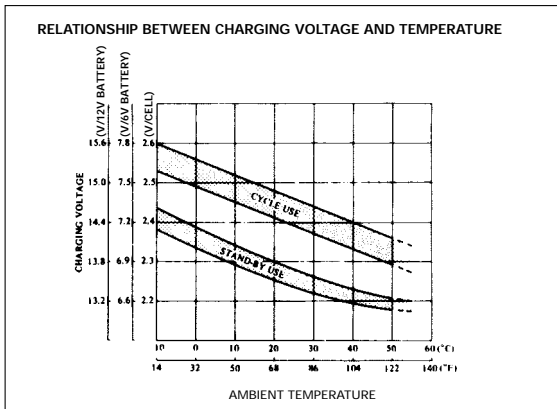

• If discharge currents in excess of 3C are required, consult an EnerSys engineer prior to use.



www.enersys.com

EnerSys
 P.O. Box 14145
 Reading, PA 19612-4145
 USA
 Tel: +1-610-208-1991
 +1-800-538-3627
 Fax: +1-610-372-8613

EnerSys EMEA
 Brussels, Belgium
 Tel: +32 (0)2 247 94 47

EnerSys Asia
 Guangdong, China
 Tel: +86-755-2689 3639

EnerSys Limited
 Rake Lane,
 Clifton Junction,
 Swinton, Manchester
 M27 8LR, UK
 Tel: +44 (0)161 794 4611
 Fax: +44 (0)161 727 3809

Contact: